



## ELPM300-48D, DC UPS Power Supply Installation and Operation Manual *Effective: March, 2005*

Alpha Technologies ®

# *Power*

---

# FlexNet ELPM 300-48D

## Installation and Operation Manual

010-322-C0-002, Rev B.

Effective Date: March, 2005  
Copyright© 2005  
Alpha Technologies, Inc.  
A Member of the Alpha Group



---

**NOTE:**

Photographs contained in this manual are for illustrative purposes only. These photographs may not match your installation.



---

**NOTE:**

Operator is cautioned to review the drawings and illustrations contained in this manual before proceeding. If there are questions regarding the safe operation of this powering system, please contact Alpha Technologies or your nearest Alpha representative.



---

**NOTE:**

Alpha shall not be held liable for any damage or injury involving its enclosures, power supplies, generators, batteries, or other hardware if used or operated in any manner or subject to any condition not consistent with its intended purpose, or is installed or operated in an unapproved manner, or improperly maintained.

Contacting Alpha Technologies: *www.alpha.com*

OR

For general product information and customer service (7 AM to 5 PM, Pacific Time), call

**1-800-863-3930**

For complete technical support, call

**1-800-863-3364**

*7 AM to 5 PM, Pacific Time or 24/7 emergency support*

# Table of Contents

Safety Information .....	5
1.0 Installation .....	10
1.1 Introduction .....	10
1.2 FlexNet Installation .....	11
1.3 Battery and RTS Probe Installation .....	12
1.4 Output Connections .....	13
1.5 Status Monitoring Connections .....	13
1.6 Status LEDs .....	14
1.7 AC Input Power Connection .....	14
1.8 Battery Connection .....	14
1.9 Output Distribution Board (optional) .....	15
2.0 Specifications .....	16
2.1 ELPM300-48D DC Power Supply .....	16
2.2 Output Distribution Board .....	17
2.3 FlexNet Installation Kit and Options.....	18

## List of Figures

Fig. 1-1 Top view, Mounting Bracket Extension Range .....	11
Fig. 1-2 Front view, ELPM 300-48D .....	11
Fig. 1-3 Battery Layout, RTS placement.....	12

## Safety Information

Review the drawings and illustrations contained in this manual before proceeding. If there are any questions regarding the safe installation or operation of the system, contact Alpha Technologies or the nearest Alpha representative. Save this document for future reference.

To reduce the risk of injury or death and to ensure the continued safe operation of this product, the following symbols have been placed throughout this manual. Where these symbols appear, use extra care and attention.

### ATTENTION:

---

ATTENTION! is used for specific regulatory/code requirements that may affect the placement of equipment and /or installation procedures.



### NOTE:

---

NOTE gives readers additional information to help them complete a specific task or procedure.



### CAUTION!

---

CAUTION! presents safety information to PREVENT DAMAGE TO customers' equipment.



### WARNING!

---

A WARNING presents safety information to PREVENT INJURY OR DEATH to the technician or user.

# General Safety Precautions

## *To avoid injury:*

- This enclosure and its associated hardware must be serviced only by authorized personnel.
- Enclosure must remain locked at all times, except when authorized service personnel are present.
- Remove all conductive jewelry or personal equipment prior to servicing equipment, parts, connectors, wiring, or batteries.
- Read and follow all installation, equipment grounding, usage, and service instructions included in this manual.
- Use proper lifting techniques whenever handling enclosure, equipment, parts, or batteries.
- Batteries contain dangerous voltages, currents and corrosive material. Battery installation, maintenance, service and replacement must be performed by authorized personnel only.
- Never use uninsulated tools or other conductive materials when installing, maintaining, servicing or replacing batteries.
- Use special caution when connecting or adjusting battery cabling. An improperly connected battery cable or an unconnected battery cable can result in arcing, a fire, or possible explosion.
- A battery that shows signs of cracking, leaking or swelling must be replaced immediately by authorized personnel using a battery of identical type and rating.
- Avoid any contact with gelled or liquid emissions from a valve-regulated lead-acid (VRLA) battery. Emissions contain dilute sulfuric acid which is harmful to the skin and eyes. Emissions are electrolytic, which are electrically conductive and are corrosive. Follow the Chemical Hazards notes if contact occurs.
- Do not smoke or introduce sparks in the vicinity of a battery.
- Under certain overcharging conditions, lead-acid batteries can vent a mixture of hydrogen gas that is explosive. Proper venting of the enclosure is required.
- Follow the battery manufacturer's approved transportation and storage instructions.



## **CAUTION!**

Enclosure, equipment or parts may be damaged or cause damage if used or installed improperly.

## *To avoid damage:*

- Prior to installation, verify that the AC input voltage to the enclosure and its equipment match with respect to voltage and frequency.
- Prior to installation, verify that the output voltage from the enclosure or its equipment match the voltage requirements of the connected equipment (load).
- Prior to installation, verify that the enclosure's utility service panel is equipped with a properly rated circuit breaker for use with the equipment inside. Refer to manufacturer's recommendations.
- Review and upgrade utility service panel circuit breaker requirements whenever the equipment within the enclosure is changed.
- Prior to installation, contact local utilities, local building maintenance departments, and cable/ piping locator services to ensure that installation does not interfere with existing utility or building cables/piping.
- Do not exceed the output rating of equipment. Verify load requirements prior and during connection process.
- Prior to handling the batteries, touch a grounded metal object to dissipate any static charge that may have developed in your body.

# Battery Safety



Lead-acid batteries contain dangerous voltages, currents and corrosive material. Battery installation, maintenance, service and replacement must be performed only by authorized personnel.

## Chemical Hazards

Any gelled or liquid emissions from a valve-regulated lead-acid (VRLA) battery contain dilute sulfuric acid, which is harmful to the skin and eyes. Emissions are electrolytic, and are electrically conductive and corrosive.

*To avoid injury:*

- Servicing and connection of batteries shall be performed by, or under the direct supervision of, personnel knowledgeable of batteries and the required safety precautions.
- Always wear eye protection, rubber gloves, and a protective vest when working near batteries. Remove all metallic objects from hands and neck.
- Batteries produce explosive gases. Keep all open flames and sparks away from batteries.
- Use tools with insulated handles, do not rest any tools on top of batteries.
- Batteries contain or emit chemicals known to the State of California to cause cancer and birth defects or other reproductive harm. Battery post terminals and related accessories contain lead and lead compounds. Wash hands after handling (California Proposition 65).
- Wear protective clothing (insulated gloves, eye protection, etc.) whenever installing, maintaining, servicing, or replacing batteries.
- If any battery emission contacts the skin, wash immediately and thoroughly with water. Follow your company's approved chemical exposure procedures.
- Neutralize any spilled battery emission with the special solution contained in an approved spill kit or with a solution of one pound Bicarbonate of soda to one gallon of water. Report chemical spill using your company's spill reporting structure and seek medical attention if necessary.
- Always replace batteries with those of an identical type and rating. Never install old or untested batteries.
- Do not charge batteries in a sealed container. Each individual battery should have at least 0.5 inches of space between it and all surrounding surfaces to allow for convection cooling.
- All battery compartments must have adequate ventilation to prevent an accumulation of potentially dangerous gas.
- Prior to handling the batteries, touch a grounded metal object to dissipate any static charge that may have developed on your body.
- Never use uninsulated tools or other conductive materials when installing, maintaining, servicing or replacing batteries.
- Use special caution when connecting or adjusting battery cabling. An improperly connected battery cable or an unconnected battery cable can make contact with an unintended surface that can result in arcing, fire, or possible explosion.
- A battery showing signs of cracking, leaking, or swelling should be replaced immediately by Authorized Personnel using a battery of identical type and rating.

# Battery Maintenance Guidelines

The battery maintenance instructions listed below are for reference only. Battery manufacturer's instructions for transportation, installation, storage or maintenance take precedence over these instructions.

- To prevent damage, inspect batteries every 3 months for:
  - **Signs of battery cracking, leaking or swelling.** The battery should be replaced immediately by authorized personnel using a battery of the identical type and rating.
  - **Signs of battery cable damage.** Battery cable should be replaced immediately by Authorized Personnel using replacement parts specified by vendor.
  - **Loose battery connection hardware.** Refer to battery manufacturer's documentation for the correct torque and connection hardware for the application.
- Apply battery manufacturer's specified antioxidant compound on all exposed connections.
- Verify battery terminals and/or exposed connection hardware is not within 2 inches of a conductive surface. Reposition batteries as necessary to maintain adequate clearance.
- Clean up any electrolyte (battery emission) in accordance with all federal, state, and local regulations or codes.
- Proper venting of the enclosure is recommended. Follow the Battery Manufacturer's approved transportation and storage instructions.
- Always replace batteries with those of an identical type and rating. Never install old or untested batteries.
- Do not charge batteries in a sealed container. Each individual battery should have at least 0.5 inches of space between it and all surrounding surfaces to allow for convection cooling.
- All battery compartments must have adequate ventilation to prevent an accumulation of potentially dangerous gas.

# Recycling and Disposal Instructions

Spent or damaged batteries are considered environmentally unsafe. Always recycle used batteries or dispose of the batteries in accordance with all federal, state and local regulations.

# Electrical Safety

- Lethal voltages are present within the power supply and electrical boxes. Never assume that an electrical connection or conductor is not energized. Check the circuit with a volt meter with respect to the grounded portion of the enclosure (both AC and DC) prior to any installation or removal procedure.
- Always use the buddy system when working under hazardous conditions.
- A licensed electrician is required to install permanently wired equipment.
- Input voltages can range up to 240 VAC. Ensure that utility power is disabled before beginning installation or removal.
- Ensure no liquids or wet clothes contact internal components.
- Hazardous electrically live parts inside this unit are energized from batteries even when the AC input power is disconnected.

# Mechanical Safety

- Keep hands and tools clear of fans. Fans are thermostatically controlled and will turn on automatically.
- Power supplies can reach extreme temperatures under load.
- Use caution around sheet metal components and sharp edges.

# Grounding Connection

In order to provide a ready, reliable source of backup power it is necessary to establish a grounding system that not only provides for the safety of the service personnel responsible for its operation and maintenance, but also facilitates the proper operation and protection of the equipment within the network. Such a grounding system will provide protection with respect to operator safety, system communication, and equipment protection.

## Safety Ground

The safety ground is a two-part system. The first part is a return path for stray current back to the input breaker, and the second is a return path from the Alpha enclosure to a second ground rod.

Typically, the safety, or utility ground, provides a return path to the input breaker or fuse panel by means of a connection to an appropriate driven ground rod at the base of the power pole. This path must meet National Electric Code (NEC) as well as local codes to ensure the breaker will open, preventing unwanted current flow from posing a hazard to service personnel.

The second part of the safety ground arrangement is the ground path between the Alpha enclosure and a second ground rod located at least 6 feet away from the driven ground rod at the power pole. The second ground rod and enclosure are connected via an AWG #6 solid copper wire buried at a depth of 8-12 inches. The wire is connected to the cabinet by means of a ground lug on the back of the cabinet (for pole-mounted enclosures), or to a ground lug inside the cabinet (for ground-mounted enclosures), and connected to the ground rod by means of a listed grounding clamp suitable for direct burial, or exothermic weld. Normally it is specified that the impedance of this ground can be no greater than 25 ohms at 60 Hertz. If, however, dual ground rods are installed approximately eight feet apart, it is not necessary to measure the impedance of the ground rods to meet the maximum 25 ohms specification—it is assumed that the impedance specification is met.

## Strike (Lightning) Ground

Lightning strikes, grid switching, or other aberrations on the power line all have the potential to cause “fast rise-time currents” which can cause damage to the powering system. Without a low-impedance path to ground, the current, while traveling through wires of varying impedance, can produce high voltages which will damage the powering equipment. The most viable method available to protect the system from damage is to divert these unwanted “fast rise-time currents” along a low-impedance path to ground. A low-impedance path to ground will prevent these currents from reaching high voltage levels and posing a threat to equipment. The single-point grounding system provides a low-impedance path to ground, and the key to its success is the proper bonding of the ground rods, so the components of the grounding system appear as a single point of uniform impedance.



### **WARNING!**

Low impedance grounding is mandatory for personnel safety and critical for the proper operation of the cable system.

# 1.0 Installation

## 1.1 Introduction

The FlexNet Fiber UPS model ELPM300-48D is a small-form, outdoor-rated, uninterruptible power supply for distributed communications networks. The unit can be installed in a variety of Alpha enclosures and is powered by 120VAC or 240VAC line input or 48VDC battery string. The 48 VDC, 300 Watt output provides uninterruptible power for various distributed communications networks.

Features and benefits:

Power Modules can be used in a variety of Alpha enclosures

Rugged 48VDC UPS for outdoor or indoor applications

Temperature compensated battery charging for extended battery life

Visual and electrical indicators for on-site and remote reporting

Flexible cabinet mounting options

Included with the unit are:

**Mounting Brackets;** see Section 1.2.

**RTS** (the Remote Temperature Sensor gets its backup power from a 48VDC battery string); See Section 1.3.

**Output Cable Kit;** see Section 1.4

**Alarm Telemetry Connector;** Status Monitoring, see Section 1.5.

Options include a Battery Heater Mat, Output Distribution Board and Battery Cable Kit.



## 1.0 Installation, continued

### 1.2 FlexNet Installation

Use #6 screws and attach mounting brackets to side of unit. Use #10 screws (at least one per side and attach unit on the mounting bar in the upper compartment of the enclosure.

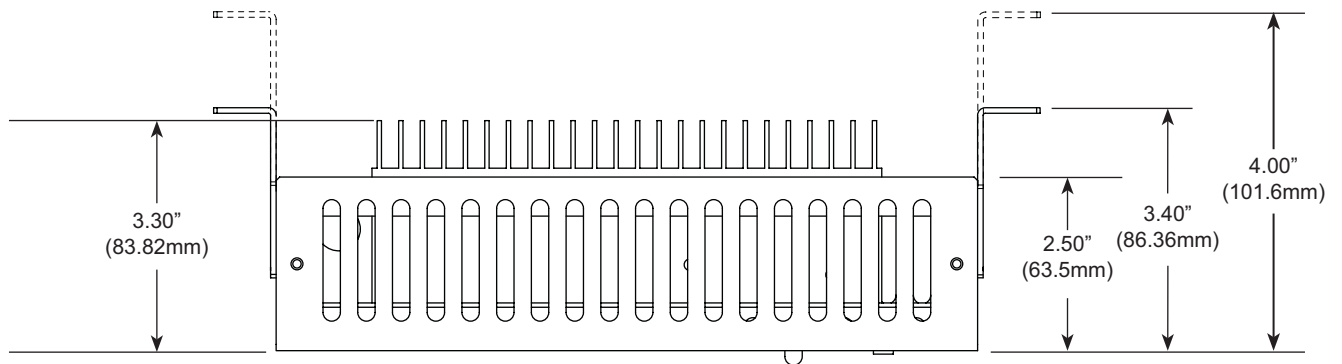

Fig. 1-1, Mounting Bracket Extension Range  
(Top view)

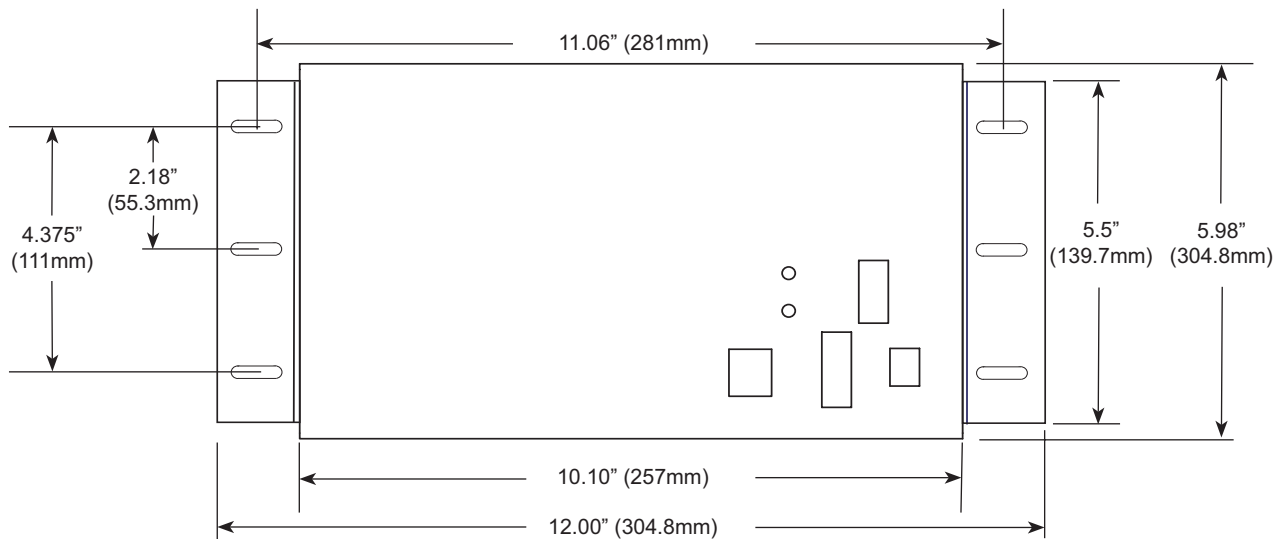

Fig. 1-2, Reference dimensions, ELPM 300-48D  
(Front view)

## 1.0 Installation, continued

### 1.3 Battery and Remote Temperature Sensor Probe Installation

The diagram below is for illustrative purposes only. Exact battery orientation may vary. **Do not** connect the batteries to the Flexnet 300 unit at this time. The RTS must be taped to the side of a center battery as shown below. Connect the other end to the RJ-11 temperature jack on the front of the power supply.

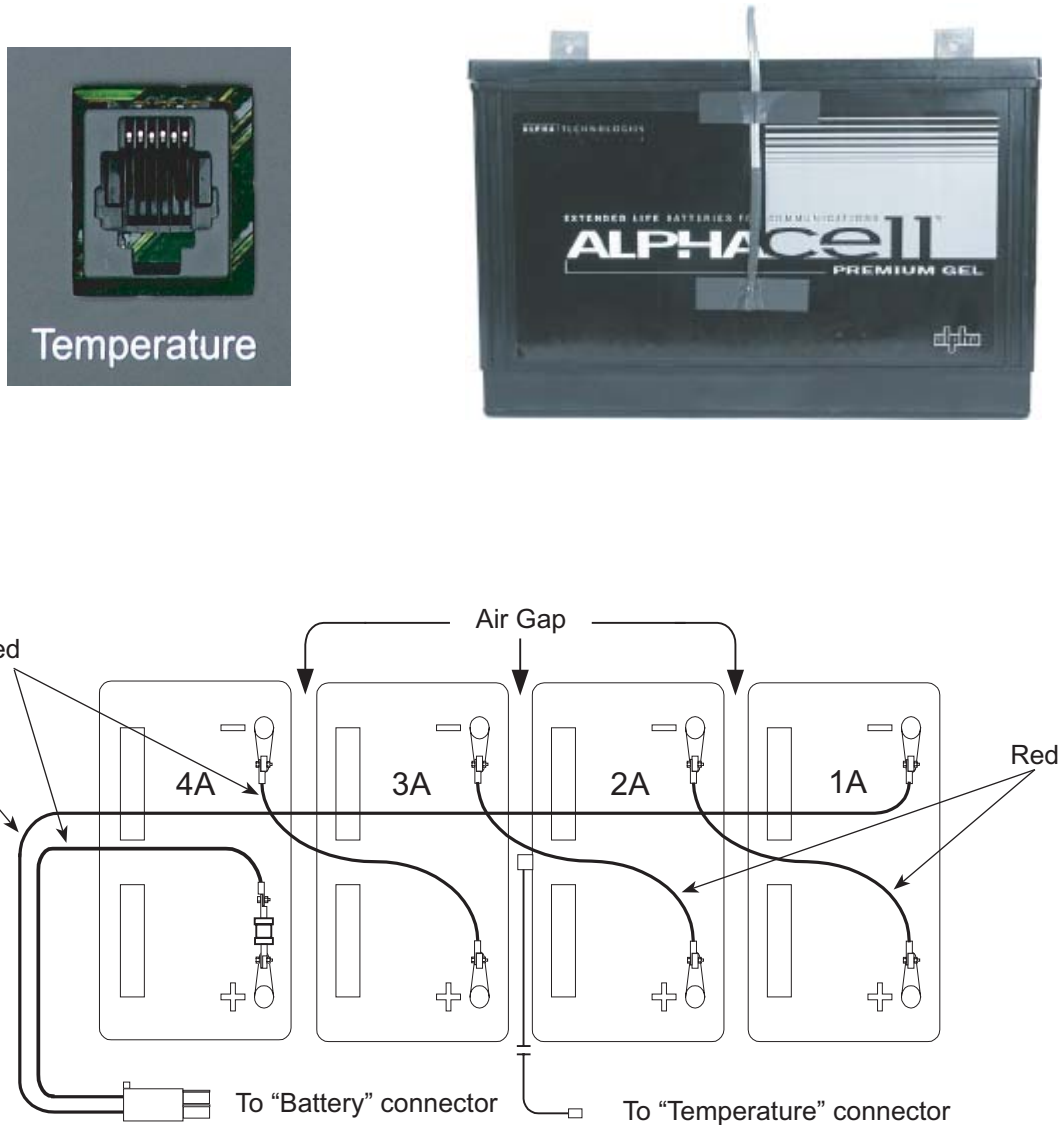
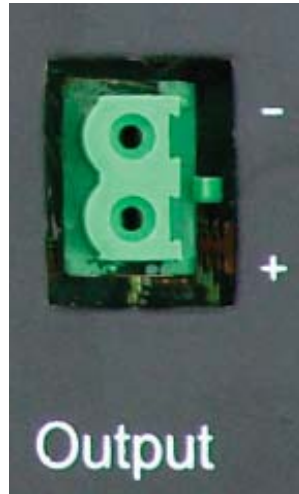

Fig. 1-3, Battery Layout and RTS Placement

## 1.0 Installation, continued

### 1.4 Output Connector

The output connection is located on the front panel of the unit. Plug the 48VDC fiber node into this connector.



### 1.5 Status Monitoring Connector

The Status Monitoring connector is located on the front panel of the unit. In the normal state the contacts are closed (NC). When an alarm is present, contacts open.



## 1.0 Installation, continued

### 1.6 Status LEDs

The status LEDs are located on the front panel of the unit. Normal operation is indicated by the green LED ON, and the red LED OFF.

LED	STATUS
Green Steady	Output OK
Green Blinking	Standby Operation
Both Blinking	Fault
Red Blinking	Batt Low / Missing
Red Steady	Replace Battery

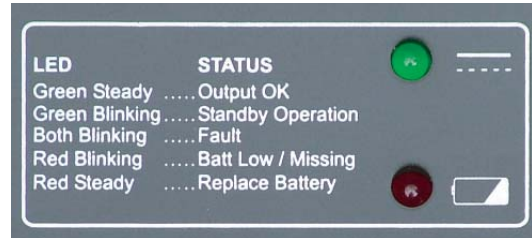

### 1.7 AC Input Power Connection

The Flexnet 300 offers switchable AC input power capability. Slide the input power switch (located on the side of the housing) to the correct voltage and plug the AC power cord into the receptacle. 230V applications require the removal of the supplied plug and replacement with a 230V plug.

Verify that the green LED is continuously illuminated and the red LED begins to blink within 20 seconds, indicating that the battery pack is not yet installed.

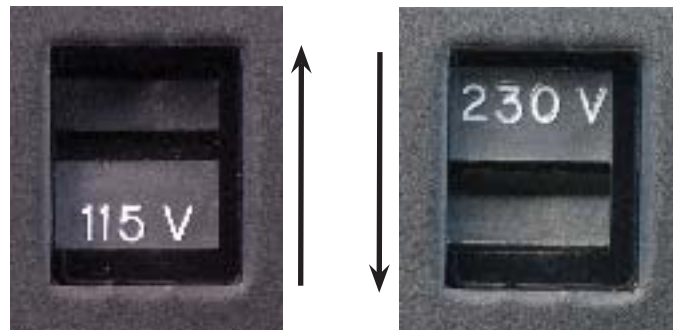

### 1.8 Battery Connection

Using a multimeter, verify that at least 48VDC is present at the connection leading from the battery pack, and the polarity is correct. If voltage of less than 48VDC is present, charge the batteries prior to connection to the unit. Connect the battery pack to the Battery connection on the front of the unit. Note the shape of the Battery connectors which prevent incorrect hookup. Verify that the red alarm LED goes out within 10 seconds.

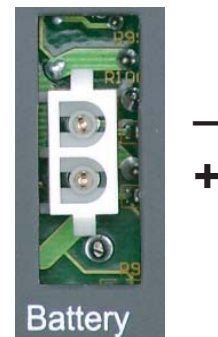

## 1.0 Installation, continued

### 1.9 Output Distribution Board (optional)

The Output Distribution Board (Alpha P/N 745-577-20) splits the ELPM300-48D's 300W output into two 150W isolated outputs. Each output has its independent protection circuit. One output overload or short circuit will only trigger its own protection and not affect the other circuit's normal operation.

The ODB measures 6.25" W x 3.875" H x 2" D (15.88cm W x 9.84cm H x 5.1cm D).

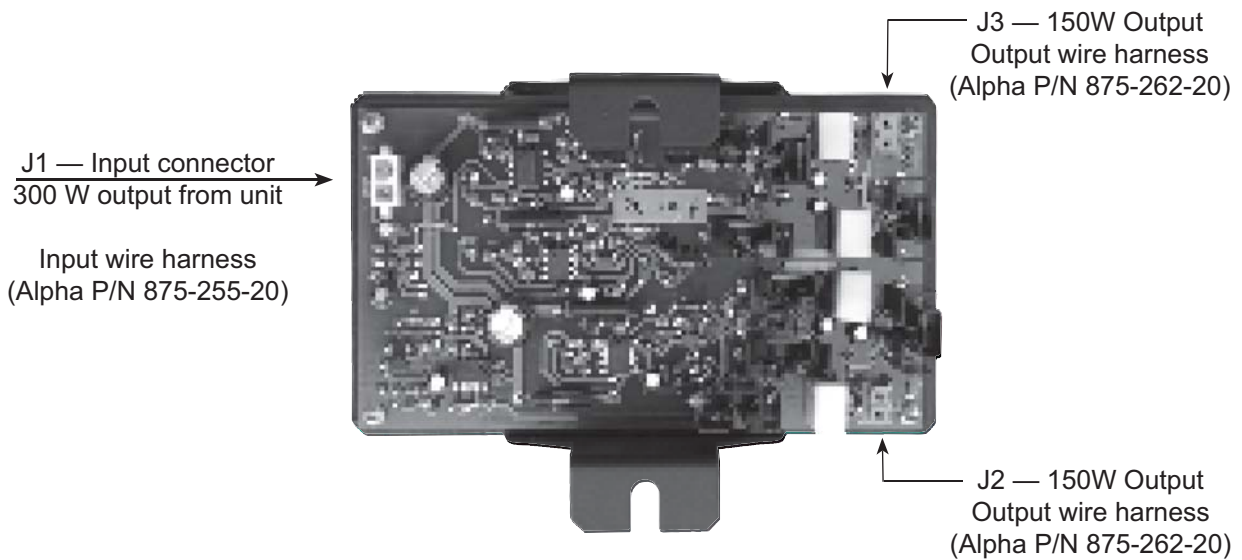

#### NOTE:

The Output Distribution board is supplied with one interconnection cable (Alpha P/N 875-255-20), and one output wire harness (Alpha P/N 875-262-20). The existing output wire harness is replaced by the interconnection cable, and is transferred to one of the output connectors.

The adapter bracket mounts to the cross bar in the enclosure, which mounts next to the power supply. Attach the Output Distribution Board to the Adapter Bracket by aligning and sliding the hanger brackets onto the bracket screws.

1. Loosen both screws enough to allow the bracket prongs to slide over the screw heads.
2. Firmly tighten only the bottom screw to secure the module.

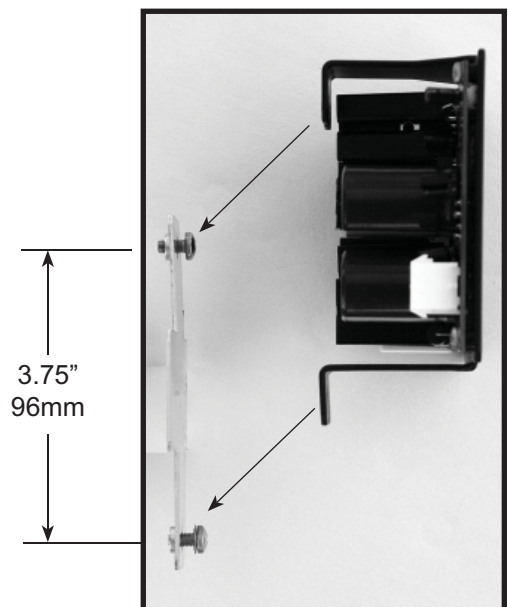

## 2.0 Specifications

### 2.1 ELP300-48D DC Power Supply

Mechanical	
Housing	Sheet metal enclosure
Mounting	Wall mounting brackets included
	Rack-mounting via optional 19-inch EIA brackets
Material	Aluminum
Finish	Painted black
Cooling	Natural convection
Acoustic Noise, Line Mode	50dBa at 1m (maximum)
Acoustic Noise, Batt Mode	50dBa at 1m (maximum)

Electrical — AC Input	
Voltage, Minimum	85/170 factory setting
Voltage, Maximum	132/264 selectable via slide switch
Frequency	50/60Hz
Frequency Tolerance	± 10%
Source Impedance	<5% FL equivalent impedance
Input Current Limit	7A
Minimum Power Factor	60%
Harmonic Input Current	Class A per CE 1000-2-3 (230Vac 50Hz)
Maximum Surge Current	50A peak
Protection	Fuse, MOV
Line Leakage	2.5mA max at 264Vac 50Hz
Surge/Transient protection	IEEE Std C62.41-1991 level C
Power Cord	3' NEMA 515 120VAC plug

Electrical Output — 48VDC	
Power Capability	320W, continuous
Voltage	40 to 59VDC (Standard Telecom Bus Voltage)
Number of Outputs	1
Startup Overshoot Range	120% of nominal, 0.5 sec. max.
Frequency	DC
Transient Response	Not to exceed 1s
Ripple Voltage, Maximum	500mV RMS
Maximum Efficiency	85% within normal operating range
Output Grounding	Floating, SELV
Short Circuit Protection	Electronic
Overload Protection	Integral
Active Load Sharing	None

## 2.0 Specifications, continued

### 2.1 ELPM300-48D DC Power Supply, continued

<b>Electrical — Battery Bus</b>	
Voltage	48VDC nominal
Recharge Time	10X Discharge Rate to 90% state of charge
Temperature Compensation Range	-20°C to +40°C
Temp. Compensation dV/dC	-72mV/°C per string
End of Discharge Voltage	42VDC (1.75V/cell)
Discharge Current	6A
Charge Current	6A
Quiescent Current	<5mA after end of discharge (EOD)
Battery Grounding	Float, SELV

<b>Electrical — Local Display</b>	
LED	STATUS
Green Steady	Output OK
Green Blinking	Standby Operation
Both Blinking	Fault
Red Blinking	Batt Low/Missing
Red Steady	Replace Battery

<b>Electrical — Status Monitor Interface</b>	
Status Monitoring Alarms	Battery Low
Voltage	Battery Missing
Number of Outputs	Replace Battery
Startup Overshoot Range	AC Fail
Frequency	Telephone Common (Signal Common)

## 2.0 Specifications, continued

### 2.2 Output Distribution Board (optional)

Electrical — General	
Efficiency	> 90%
Grounding	Positive or negative terminal (user preference)
Startup Time	< 20s

Electrical — Input	
Voltage, minimum	42VDC
Voltage, nominal	48VDC
Voltage, maximum	62VDC

Electrical — Output I/II	
Voltage, minimum	41 VDC
Voltage, maximum	61VDC
Current, nominal	3A
Output Ripple, max.	500mV RMS
Overcurrent/Short Circuit Protecting Mode	Hiccup
Protection Trigger	<10ms
Threshold	4A

Environment	
Operating Temperature	-40°C to +65°C (-40°F to +149°F)
Storage Temperature	-50°C to +70°C (-58°F to +158°F)
Solar Loading	Inclusive maximum operating temperature
Humidity	0-95%, Non-condensing
Altitude	Temp. spec applicable to 5,000ft (1524m). Above 5,000ft, de-ratemax temp 2°C per additional 1,000ft (304.8m)

Physical	
Dimensions: 6.00" H x 3.875" D 2" D (15.88cm W x 9.84cm H x 5.1cm D)	
Weight: 10lbs/4.5kg	

## 2.3 FlexNet Installation Kit and Options

The following items are part of the FlexNet installation package and options for the ELPM300-48D power supply.



### NOTE:

The optional 10" x 17" Battery Heater Mat (Alpha P/N 189-057-10) is not shown .

Battery Cable Kit (Alpha P/N 875-218-21)  
See Section 1.8



Output Cable Kit (Alpha P/N 875-262-20)  
See Section 1.4



Mounting Brackets/Hardware  
(Alpha P/N 605-564-C4)  
See Section 1.2



(RTS) Remote Temperature Sensor  
(Alpha P/N 740-162-27)  
See Section 1.3  
Alarm Telemetry Connector  
(Alpha P/N 545-866-10)



19" EIA Rack Mounting Brackets  
(Alpha P/N 604-907-00)



# Alpha Technologies ®

# Power

---

Alpha Technologies  
3767 Alpha Way  
Bellingham, WA 98226  
**USA**  
Tel: +1(360) 647-2360  
Fax: +1(360) 671-4936  
Web: [www.alpha.com](http://www.alpha.com)

Alpha Technologies Ltd.  
4084 McConnell Court  
Burnaby, BC, V5A 3N7  
**CANADA**  
Tel: +1(604) 430-1476  
Fax: +1(604) 430-8908

Alpha Technologies  
Europe Ltd.  
Cartel Business Estate  
Edinburgh Way  
Harlow, Essex CM20 2TT  
**UNITED KINGDOM**  
Tel: +44-1279-422110  
Fax: +44-1279-423355

Alpha Technologies, GmbH  
Hansastraße 8  
D-91126 Schwabach  
**GERMANY**  
Tel: +49-9122-79889-0  
Fax: +49-9122-79889-21

Alphatec, Ltd.  
339 St. Andrews Street, Suite 101  
Andrea Chambers  
3307 Limassol, Cyprus  
**CYPRUS**  
Tel: +357-25-375675  
Fax: +357-25-359595